

Quick Load Pump Head



Model No. : EasyPump(fixed pressure)
Flow Rate : 0.0053-3100mL/min



Single Channel



Dual Channel

Product Features

4 rollers, low pulsation, high precision.

The tube clamp linkage mechanism makes it more convenient to install the tube.

The rubbing wheel adjustment mechanism can easily fix different size tube.

The lever assist mechanism makes the operation more easy.

Two tubes can be installed at the same time to realize single pump head with two channels.

Parameter

Pump Head	Single/Dual Channel	Tubing Wall Thickness(mm)	Pressure Adjustable
EasyPump I	Single Channel	1.6	No
EasyPump II	Single Channel	2.4	No
EasyPump V	Dual Channel	1.6	No



EasyPump Series (Fixed Pressure)



EasyPump-PPSG Series (Fixed Pressure)



EasyPump-PPSY Series (Fixed Pressure)



Flow Rate

Pump Head	Tubing	ID×Wall thickness(mm)	mL / r	Flow Rate(mL/min) (0.1-600rpm)	Tubing Max.Pressure(Mpa)		Weight(kg)
					Intermittent	Continuous	
Single Channel EasyPump I	13#	0.8×1.6	0.053	0.0053~32	0.27	0.17	0.6
	14#	1.6×1.6	0.27	0.027~162			
	19#	2.4×1.6	0.55	0.055~330			
	16#	3.1×1.6	0.933	0.093~560	0.24	0.14	
	25#	4.8×1.6	1.967	0.197~1180	0.14	0.10	
	17#	6.4×1.6	3.333	0.333~2000	0.10	0.07	
	18#	7.9×1.6	4.3	0.430~2580			
Single Channel EasyPump II	15#	4.8×2.4	1.8	0.180~1080	0.27	0.17	
	24#	6.4×2.4	2.733	0.273~1640	0.24	0.14	
	35#	7.9×2.4	3.833	0.383~2300			
	36#	9.6×2.4	5.167	0.517~3100			
Dual Channel EasyPump V	13#	0.8×1.6	0.0053	0.0053~32	0.27	0.17	
	14#	1.6×1.6	0.27	0.027~162			
	19#	2.4×1.6	0.55	0.055~330			
	16#	3.1×1.6	0.933	0.093~560	0.24	0.14	
	25#	4.8×1.6	1.967	0.197~1180			

Dimension Drawing (Unit:mm)

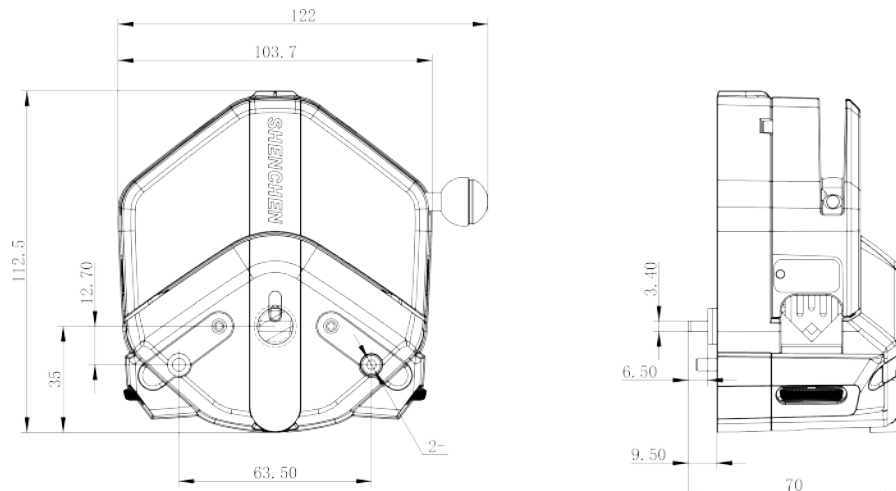



Tubing Installation

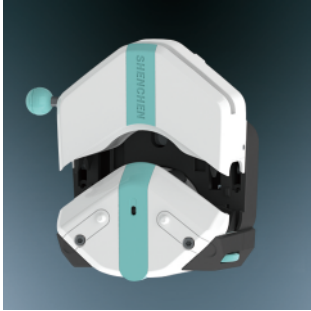

1. Turn the knob anticlockwise 180°, open the upper block.

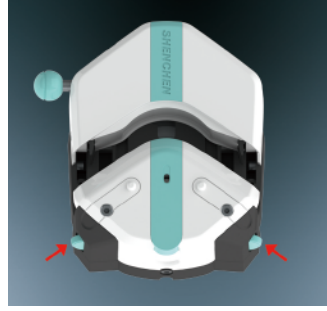

2. Rubbing wheel adjustment.

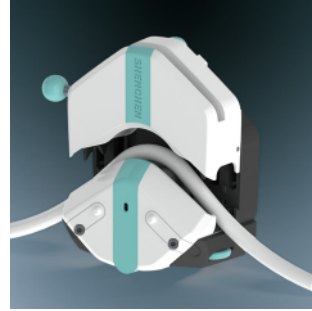

3. Put the tube between rollers and upper block, tighten up the tubing lightly.

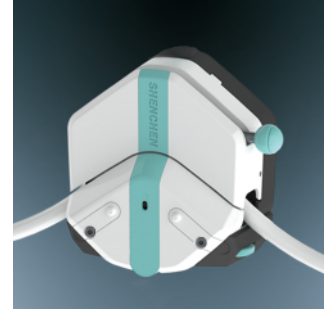

4. Turn the knob clockwise 180°, put the upper block back to original position, fasten the tube.