

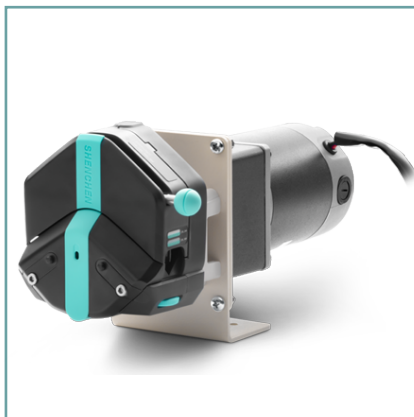

Model No. : OEM-J022/EasyPump

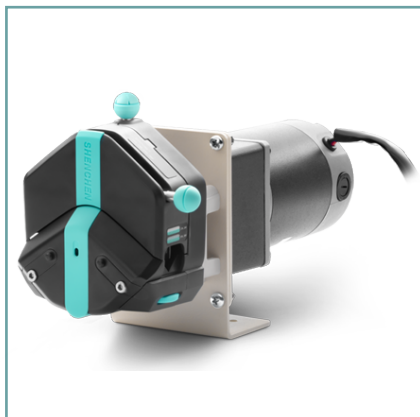

Flow Data

Pump Head	Tubing	ID×Wall thickness(mm)	mL / r	Flow Rate(mL/min) (0.1-430rpm)	Tubing Max.Pressure(Mpa)		Weight(kg)
					Intermittent	Continuous	
Single Channel EasyPump I/III	13#	0.8×1.6	0.053	0.0053~22.79	0.27	0.17	0.6
	14#	1.6×1.6	0.27	0.027~116.1			
	19#	2.4×1.6	0.55	0.055~236.5			
	16#	3.1×1.6	0.933	0.093~401.19	0.24	0.14	
	25#	4.8×1.6	1.967	0.197~845.81			
	17#	6.4×1.6	3.333	0.333~1433.19			
	18#	7.9×1.6	4.3	0.430~1849			
Single Channel EasyPump II/ IV	15#	4.8×2.4	1.8	0.180~774	0.27	0.17	
	24#	6.4×2.4	2.733	0.273~1175.19			
	35#	7.9×2.4	3.833	0.383~1648.19	0.24	0.14	
	36#	9.6×2.4	5.167	0.517~2221.81			
Dual Channel EasyPump V/VI	13#	0.8×1.6	0.0053	0.0053~22.79	0.27	0.17	
	14#	1.6×1.6	0.27	0.027~116.1			
	19#	2.4×1.6	0.55	0.055~236.5			
	16#	3.1×1.6	0.933	0.093~401.19			
	25#	4.8×1.6	1.967	0.197~845.81	0.24	0.14	



Motor Specification

Model No.	OEM-J022/EasyPump
Motor type	AC geared motor
Power supply	AC220V/AC110V
Speed	430rpm
Speed error	≤±10%
Working environment	0-40°C, 80%RH

Dimension Drawing (Unit:mm)

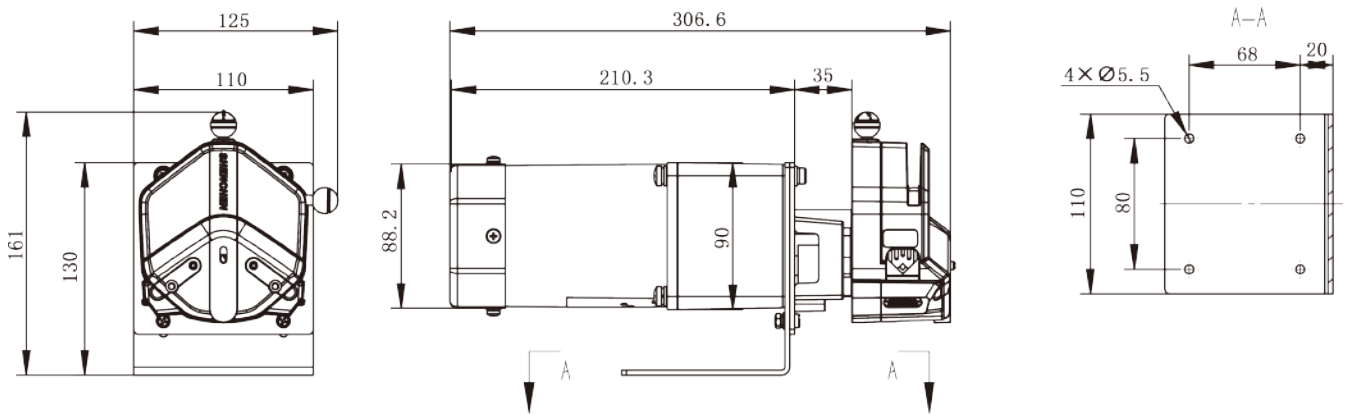

Tubing Installation Procedure



1. Turn the knob anticlockwise 180°, open the upper block.

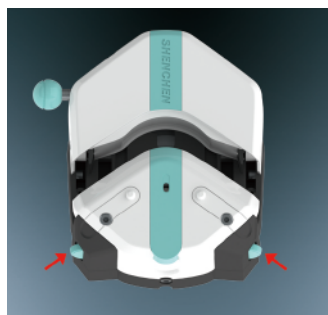

2. Turn the rubbing wheel to adjust the lower tube clamp position, according to the tubing size.



3. Put the tube between rollers and upper block, tighten up the tubing lightly.

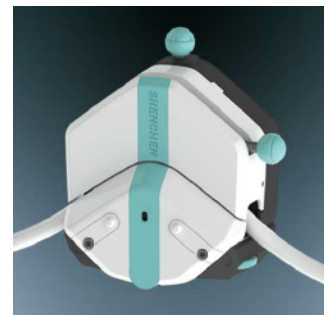

4. Turn the knob clockwise 180°, put the upper block back to original position, fasten the tube.