

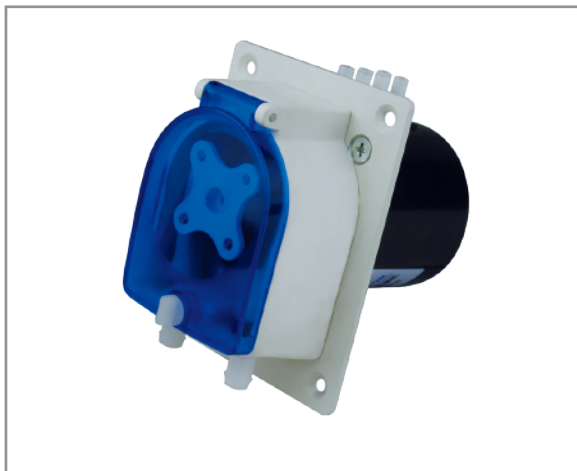

Model No. : OEM-UJ Series



Product Introduction

PES material, transparent protecting cover, easily to observe the working situation of pump head and tubing at any time. Various of colors are available. There is water-proof groove in the pump head mounting side. Can use stepper motor, DC motor, AC motor and so on to drive.

Typical Application

Widely used in industrial washing machines, dishwashers, fermentation tanks, analytical instruments supporting.

Flow Data

Pump Head	Housing Material		Tubing		Speed Range(rpm)	Flow Rate (mL/min)	Weight (kg)
	Body	Protective cover	Tubing Sizes	ID×Wall Thickness			
UD15	PSF	Transparent PC	16#	3.1×1.6	0.1-350	0.08-280	0.12
			25#	4.8×1.6		0.16-580	
			17#	6.4×1.6		0.26-930	

Motor Specification

Model No.	Motor Type	Power Supply	Motor Speed(rpm±10%)	Flow Rate(mL/min)
OEM-UJ010	AC motor	AC220V	80	≤212
OEM-UJ21	Φ70 ACmotor		350	≤930



Dimension Drawing (Unit:mm)

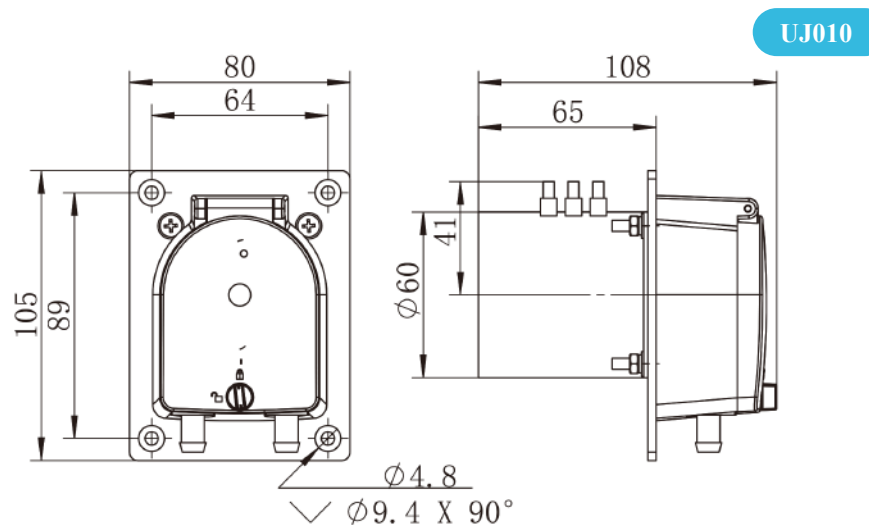
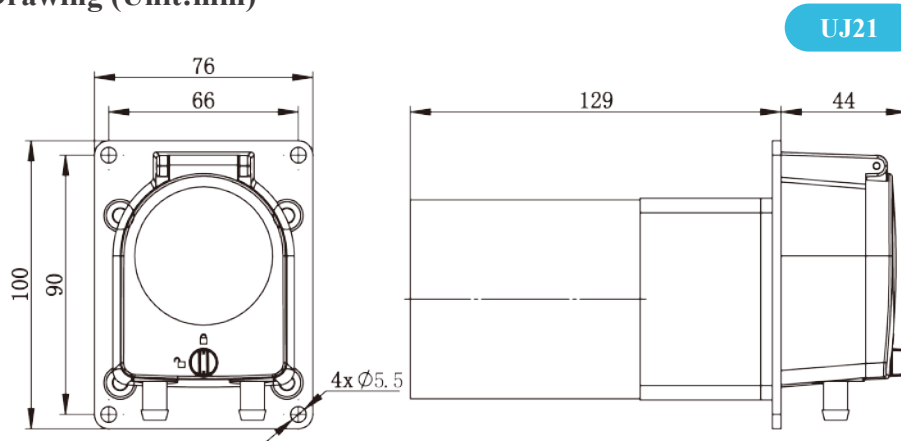

Tubing Installation Procedure



A. As below picture, turn the holding pin to unlocking position.

B. Open the transparent cover.

C. Install the tubing.

D. Close the transparent cover, and turn the holding pin to unlocking position.