

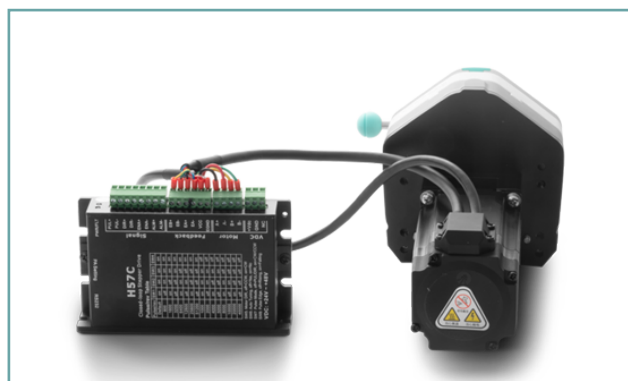

Model No. : OEM-EYB302



Flow Data

Pump Head	Tubing	ID×Wall thickness(mm)	mL / r	Flow Rate(mL/min) (0.1-600rpm)	Tubing Max.Pressure(Mpa)		Weight(kg)
					Intermittent	Continuous	
Single Channel EasyPump I/III	13#	0.8×1.6	0.053	0.0053~32	0.27	0.17	0.6
	14#	1.6×1.6	0.27	0.027~162			
	19#	2.4×1.6	0.55	0.055~330			
	16#	3.1×1.6	0.933	0.093~560	0.24	0.14	
	25#	4.8×1.6	1.967	0.197~1180	0.14	0.10	
	17#	6.4×1.6	3.333	0.333~2000	0.10	0.07	
	18#	7.9×1.6	4.3	0.430~2580			
Single Channel EasyPumpII/ IV	15#	4.8×2.4	1.8	0.180~1080	0.27	0.17	
	24#	6.4×2.4	2.733	0.273~1640	0.24	0.14	
	35#	7.9×2.4	3.833	0.383~2300			
	36#	9.6×2.4	5.167	0.517~3100			
Dual Channel EasyPump V/VI	13#	0.8×1.6	0.0053	0.0053~32	0.27	0.17	
	14#	1.6×1.6	0.27	0.027~162			
	19#	2.4×1.6	0.55	0.055~330			
	16#	3.1×1.6	0.933	0.093~560	0.24	0.14	
	25#	4.8×1.6	1.967	0.197~1180			



Motor Specification

Model No.	OEM-EYB302
Speed range	0.1-600rpm
Flow rate range	0.0053-3100mL/min
Speed control	External input pulse frequency speed control
Subdivision settings	4-speed DIP switch setting(default 16 subdivisions)
Current setting	Adaptive current
Motor type	57 Closed-loop stepper motor
Power supply	DC18~50V(recommend36V),≥80W
Logic input voltage	5V
Working environment	0-40°C, 80%RH

Dimension Drawing (Unit:mm)

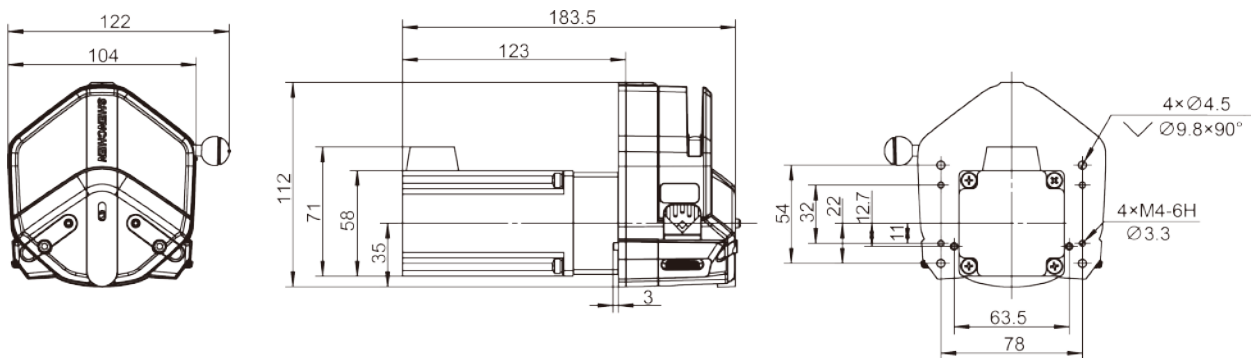

Tubing Installation Procedure



1. Turn the knob anticlockwise 180°, open the upper block.

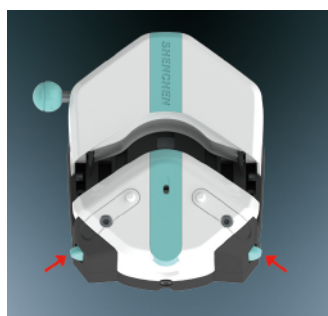

2. Turn the rubbing wheel to adjust the lower tube clamp position, according to the tubing size.



3. Put the tube between rollers and upper block, tighten up the tubing lightly.

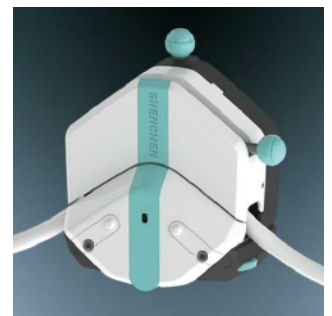

4. Turn the knob clockwise 180°, put the upper block back to original position, fasten the tube.